

ESJ75SH120FE

Trench/Fieldstop IGBT module

■ Features

- Low $V_{CE(sat)}$
- $BV_{CES} = 1250V$
- Fast & Soft Anti-Parallel FWD
- Short circuit rated : Min. 5 μ s at $T_C=25^\circ C$
- Reduced EMI and RFI
- Isolation Type Package

■ Applications

- Welding Machine
- Induction Heating
- UPS Systems

Equivalent Circuit and Package

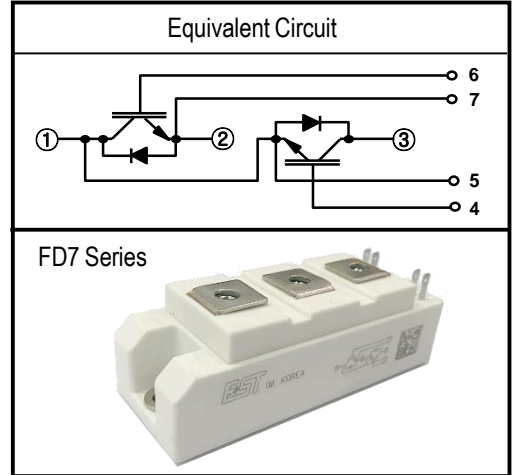

Please see the package out line information

■ Absolute Maximum Ratings @ $T_C=25^\circ C$ (Per Leg)

Symbol	Parameter	Conditions	Ratings	Unit
V_{CES}	Collector-emitter voltage	-	1250	V
V_{GES}	Gate-emitter peak voltage	-	± 30	V
I_C	DC-collector current	$T_C = 25^\circ C$	110	A
		$T_C = 80^\circ C$	75	A
$I_{CM}^{(1)}$	Repetitive peak collector current	1ms	150	A
I_F	Diode continuous forward current	$T_C = 80^\circ C$	75	A
I_{FM}	Diode repetitive peak forward current	-	150	A
$T_j^{(2)}$	Operating junction temperature	-	-40 ~ 125	$^\circ C$
T_{stg}	Storage temperature range	-	-40 ~ 125	$^\circ C$
V_{ISO}	Insulation test voltage	60Hz, t=1min $I_{ISOL}=1mA$	2.5	kV
M_S	Mounting screw torque	M6	3.0 ~ 6.0	N.m
M_t	Mounting terminals screw torque	M5	2.5 ~ 5.0	N.m

(Note *1) Repetitive rating : Pulse width limited by max junction temperature

(Note *2) The maximum junction temperature of chip is 150 $^\circ C$

Electrical Characteristics of IGBT @ $T_c=25^\circ\text{C}$ (unless otherwise specified)

Symbol	Parameter	Conditions	Min.	Typ.	Max.	Unit
BV_{CES}	C - E Breakdown Voltage	$V_{GE} = 0V, I_C = 100\mu A$	1250	-	-	V
$V_{GE(th)}$	G-E threshold voltage	$I_C = 1mA, V_{CE} = V_{GE}$	5.0	-	7.0	V
I_{CES}	Zero gate voltage collector current	$V_{GE} = 0V, V_{CE} = 1250V$	-	-	100	μA
I_{GES}	G-E leakage current	$V_{GE} = \pm 20V, V_{CE} = 0V$	-	-	± 0.5	μA
$V_{CE(Sat)}$	C-E saturation voltage	$I_C = 75A, V_{GE} = 15V, T_J = 25^\circ\text{C}$	-	2.1	2.5	V
		$I_C = 75A, V_{GE} = 15V, T_J = 125^\circ\text{C}$	-	2.4	-	V
C_{ies}	Input capacitance	$V_{GE} = 0V, f = 1MHz, V_{CE} = 25V$	-	6980	-	pF
C_{oes}	Output capacitance		-	367	-	
C_{res}	Reverse transfer capacitance		-	190	-	
$td(on)$	Turn-on delay time	$V_{CE} = 600V, I_C = 75A,$ $V_{GE} = \pm 15V, R_G = 15\Omega,$ $T_J = 25^\circ\text{C},$ $L = 100\mu H$	-	175	-	ns
tr	Turn-on rise time		-	145	-	
$td(off)$	Turn-off delay time		-	310	-	
tf	Turn-off fall time		-	65	-	
E_{on}	Turn-on Energy loss		-	6.9	-	
E_{off}	Turn-off Energy loss	-	3.5	-		
$td(on)$	Turn-on delay time	$V_{CE} = 600V, I_C = 75A,$ $V_{GE} = \pm 15V, R_G = 15\Omega,$ $T_J = 125^\circ\text{C},$ $L = 100\mu H$	-	175	-	ns
tr	Turn-on rise time		-	190	-	
$td(off)$	Turn-off delay time		-	330	-	
tf	Turn-off fall time		-	145	-	
E_{on}	Turn-on Energy loss		-	8.5	-	
E_{off}	Turn-off Energy loss	-	4.4	-		
T_{sc}	Short Circuit Withstand Time	$V_{CC} = 600V, V_{GE} = 15V, @T_c = 25^\circ\text{C}$	5	-	-	μs
Q_g	Total gate charge	$V_{GE} = \pm 15V, V_{CE} = 600V, I_C = 75A$	-	442	-	nC

Electrical Characteristics of FRD @ $T_C=25^\circ\text{C}$ (unless otherwise specified)

Symbol	Parameter	Conditions	Min.	Typ.	Max.	Unit	
V_{FM}	Diode Forward Voltage	$I_F=75\text{A}$	$T_J=25^\circ\text{C}$	-	2.3	2.7	V
			$T_J=125^\circ\text{C}$	-	2.3	-	
t_{rr}	Diode Reverse Recovery Time		$T_J=25^\circ\text{C}$	-	150	180	ns
			$T_J=125^\circ\text{C}$	-	185	-	
I_{rr}	Diode Peak Reverse Recovery Current	$I_F=75\text{A}, V_R=600\text{V}$ $di/dt=-1000\text{A}/\mu\text{S}$	$T_J=25^\circ\text{C}$	-	70	-	A
			$T_J=125^\circ\text{C}$	-	75	-	
Q_{rr}	G-E leakage current		$T_J=25^\circ\text{C}$	-	5250	-	nC
			$T_J=125^\circ\text{C}$	-	6937	-	

Thermal Characteristics and Weight

Symbol	Parameter	Conditions	Min.	Typ.	Max.	Unit
$R_{\theta JC}$	Junction-to-Case	per IGBT	-	-	0.39	$^\circ\text{C}/\text{W}$
$R_{\theta JC}$	Junction-to-Case	per DIODE	-	-	0.46	$^\circ\text{C}/\text{W}$
$R_{\theta CK}$	Case-to-Heatsink (Conductive grease applied)	per IGBT	0.05	-	-	$^\circ\text{C}/\text{W}$
Weight	Weight of Module		-	-	160	g

Performance Curves

Fig. 1 Typical IGBT output characteristics ($T_J = 25^\circ\text{C}$)

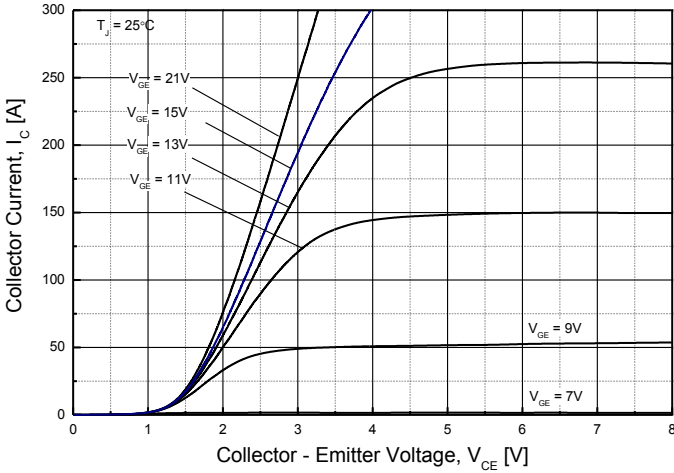

Fig. 2 Typical IGBT output characteristics ($T_J = 125^\circ\text{C}$)

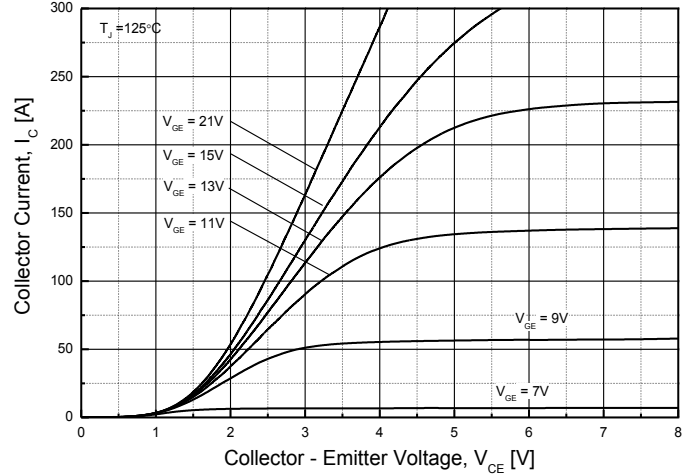

Fig. 3 Typical IGBT output characteristics

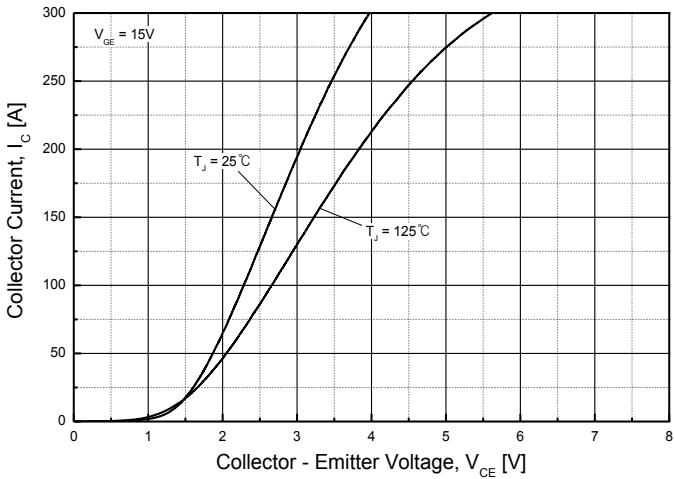

Fig. 4 Typical diode forward characteristics

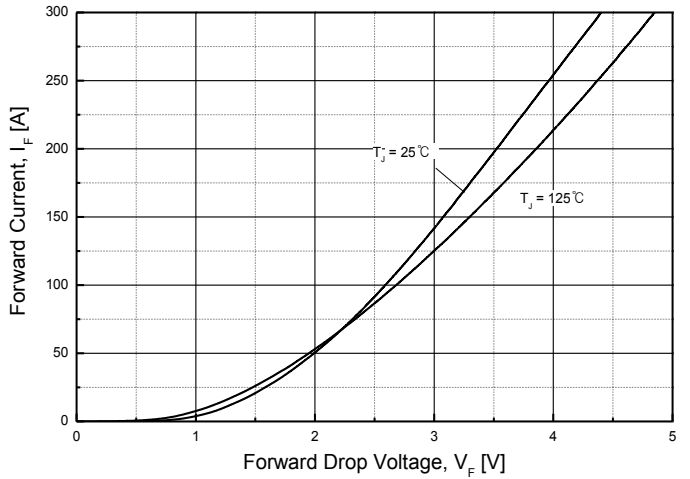

Fig. 5 Typical Switching Energy Loss = $f(R_G)$
 $V_{GE} = \pm 15V, I_C = 75A, V_{CE} = 600V, T_J = 25^\circ\text{C}$

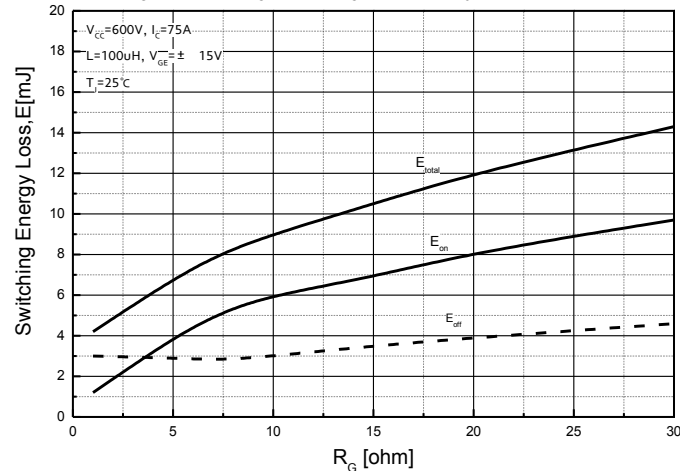
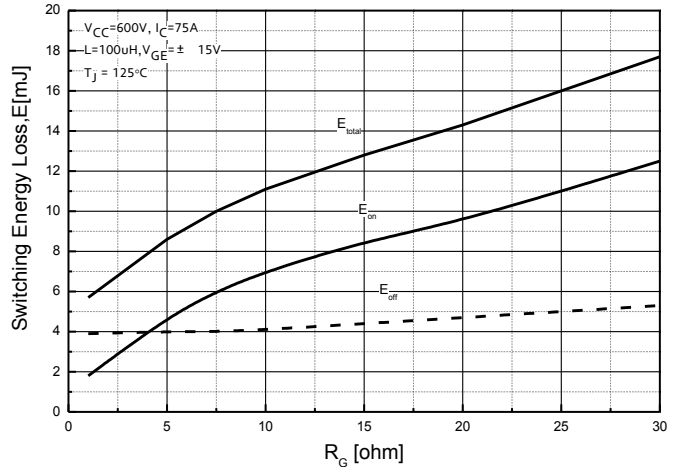

Fig. 6 Typical Switching Energy Loss = $f(R_G)$
 $V_{GE} = \pm 15V, I_C = 75A, V_{CE} = 600V, T_J = 125^\circ\text{C}$



Performance Curves

Fig. 7 Typical Switching Energy Loss =f(I_c)
 $V_{GE} = \pm 15V, R_G = 15\Omega, V_{CE} = 600V, T_j = 25^\circ C$

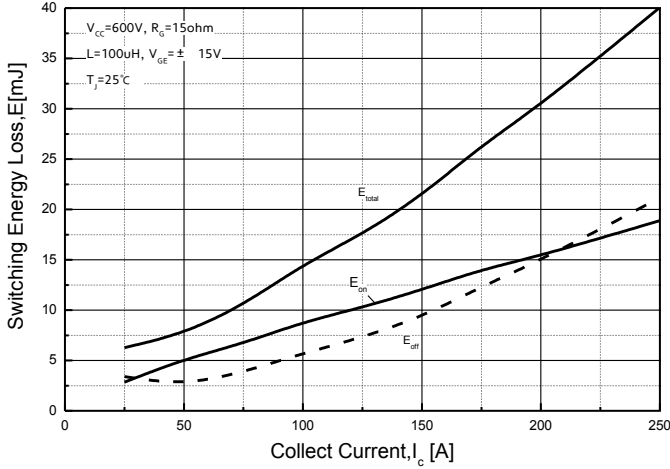

Fig. 8 Typical Switching Energy Loss =f(I_c)
 $V_{GE} = \pm 15V, R_G = 15\Omega, V_{CE} = 600V, T_j = 125^\circ C$

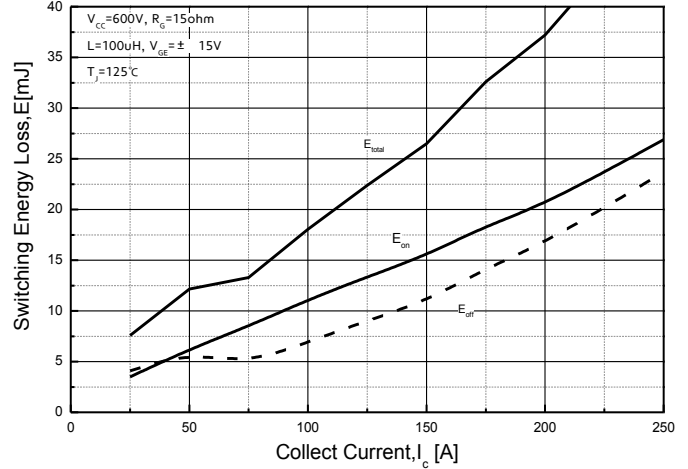

Fig. 9 Gate Charge Characteristics

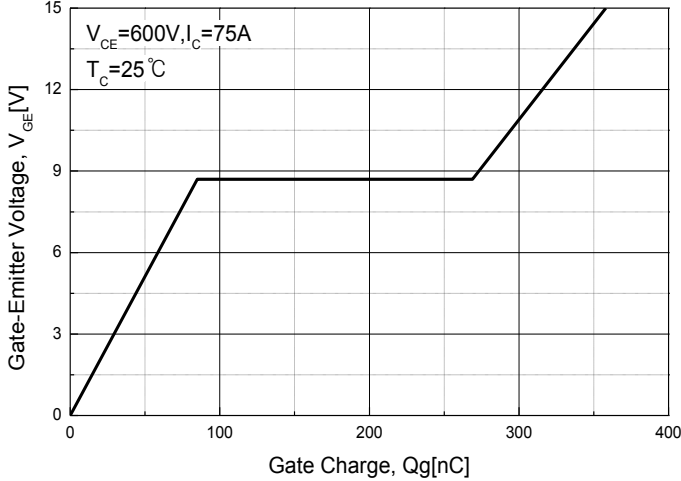
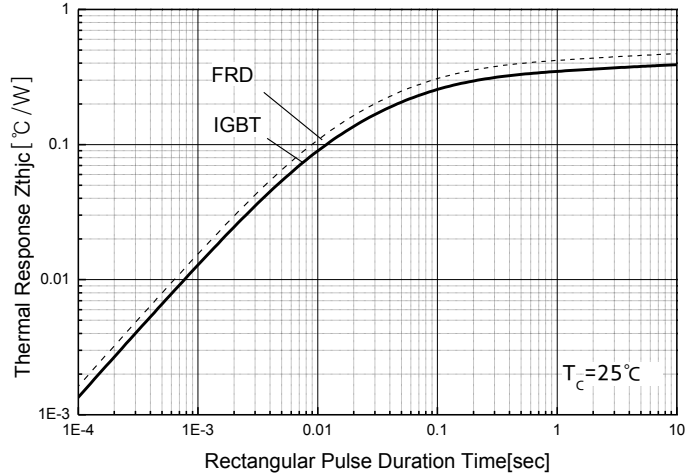

Fig. 10 Transient Thermal Resistor



■ Package Out Line Information

FD7 Package

Dimensions in mm

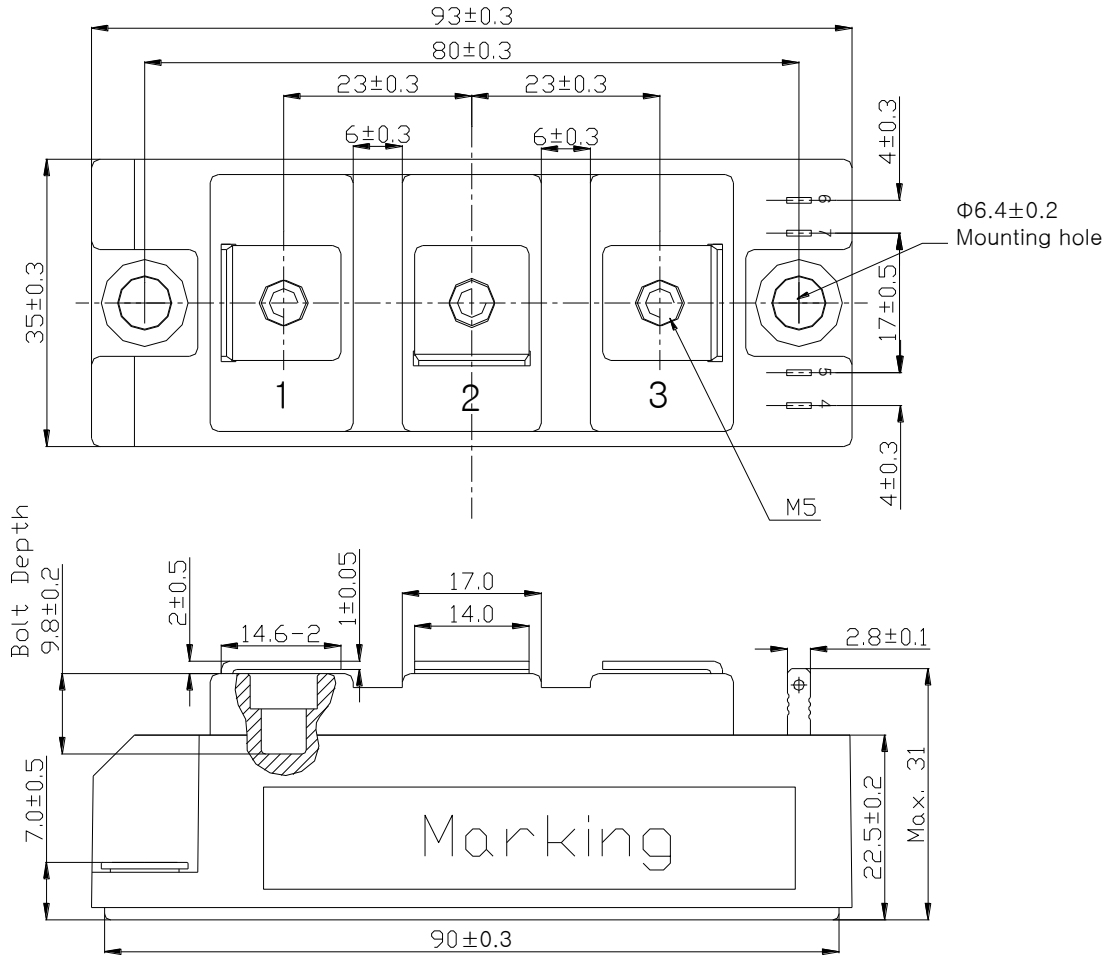

■ Internal Circuit

