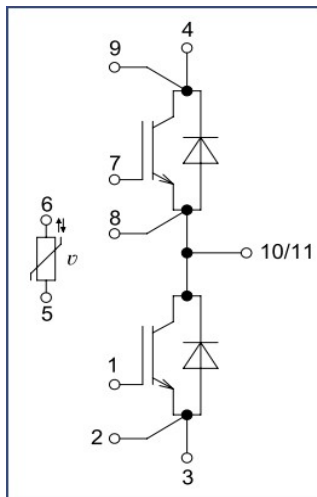
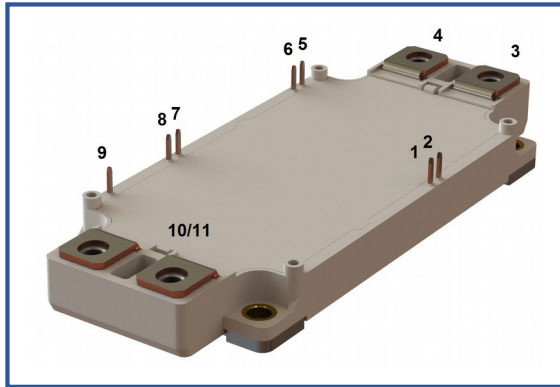

Low Inductance IGBT Module with 17 mm Height Housing
1700 V 300 A

Chip features

- IGBT chip
 - Trench FS — V-Series IGBT (6th gen)
 - low $V_{CE(sat)}$ value
 - 10 μ s short circuit duration at 150°C
 - square RBSOA of 2xlc
 - low EMI
- FRD chip
 - fast and soft reverse recovery
 - low voltage drop

Design features

- copper baseplate
- Al_2O_3 DBC substrate
- ultrasonic welded power terminals
- improved thermal cycling
- RoHS compliant

Typical application

- AC motor drives
- solar inverters
- air conditioning
- high power converters and UPS
- Inverters for wind energy converters

Maximum rated values

Definition	Symbol	Conditions	Value	Unit
IGBT				
Collector-Emitter voltage	V_{CES}	$V_{GE} = 0$.	1700	V
Collector current (nominal)	$I_{C\ nom}$		300	A
Collector current (maximum continuous)	$I_{C\ 25}$	$T_{vj\ (max)} = 175^\circ C; T_c = 25^\circ C$.	460	A
	$I_{C\ 80}$	$T_{vj\ (max)} = 175^\circ C; T_c = 80^\circ C$.	300	A
Repetitive peak collector current*1	I_{CRM}	$I_{CRM} = 3 \times I_{C\ nom}; t_p = 1\ ms$.	900	A
Short-circuit duration	t_{psc}	$T_{vj} = 25^\circ C; V_{GE} = \pm 15\ V; V_{CE} = 1000\ V;$ $R_{G\ on} = R_{G\ off} = 3\ \Omega$	10	μ s
		$T_{vj} = 150^\circ C; V_{GE} = \pm 15\ V; V_{CE} = 1000\ V;$ $R_{G\ on} = R_{G\ off} = 3\ \Omega$	10	
Gate-Emitter voltage	V_{GES}		± 20	V
Junction operating temperature	$T_{vj\ (op)}$		-40...+150	°C
Inverse diode \ Freewheeling diode				
Repetitive peak reverse voltage	V_{RRM}	$V_{GE} = 0\ V$.	1700	V
Forward current (nominal)	$I_{F\ nom}$		300	A
Forward current (maximum continuous)	$I_{F\ 25}$	$T_{vj\ (max)} = 175^\circ C; T_c = 25^\circ C$.	352	A
	$I_{F\ 80}$	$T_{vj\ (max)} = 175^\circ C; T_c = 80^\circ C$.	300	A
Repetitive peak forward current*1	I_{FRM}	$I_{FRM} = 3 \times I_{F\ nom}; t_p = 1\ ms$.	900	A
Junction operating temperature	$T_{vj\ (op)}$		-40...+150	°C
Module				
Storage temperature	T_{stg}		-55...+50	°C
Isolation voltage	V_{isol}	AC sin 50 Hz; t = 1 min.	4000	V

*1 Pulse width and repetition rate should be such that device junction temperature does not exceed maximum T_{vj} rating

Characteristics

Definition	Symbol	Conditions	Value			Unit		
			min.	typ.	max.			
IGBT								
Collector-Emitter saturation voltage	V_{CEsat}	$V_{GE} = +15\text{ V}; I_C = 300\text{ A}; t_u = 1000\ \mu\text{s}.$	$T_{vj} = 25^\circ\text{C}$ $T_{vj} = 150^\circ\text{C}$	2.16 2.77	2.21 2.87	2.42 3.14	V V	
Gate-Emitter threshold voltage	$V_{GE(th)}$	$I_C = 18\text{ mA}; V_{CE} = V_{GE}; T_{vj} = 25^\circ\text{C}; t_u = 2\text{ ms}.$		5.30	5.83	6.70	V	
Collector-Emitter cut-off current	I_{CES}	$V_{CE} = 1700\text{ V}; t_u = 50\text{ ms}; V_{GE} = 0.$	$T_{vj} = 25^\circ\text{C}$ $T_{vj} = 150^\circ\text{C}$	1.51 0.84	1.70 1.02	150 2.50	μA mA	
Gate-Emitter leakage current	I_{GES}	$V_{CE} = 0; V_{GE} = \pm 20\text{ V}; T_{vj} = 25^\circ\text{C}; t_u = 30\text{ ms}.$		9.50	12.1	200	nA	
Input capacitance	C_{ies}	$V_{CE} = 10\text{ V}; V_{GE} = 0\text{ V}; f = 1\text{ MHz}; T_{vj} = 25^\circ\text{C}.$		-	29.7	-	nF	
Output capacitance	C_{oes}		-	-	1.5	-	nF	
Reverse transfer capacitance	C_{res}		-	-	2.4	-	nF	
Total gate charge	Q_G	$I_{Cmax} = 300\text{ A}; V_{CE} = 920\text{ V}; V_{GE} = -8 \div 15\text{ V}.$		-	3428	3550	nC	
Internal gate resistance	R_{Gint}	$T_{vj} = 25^\circ\text{C}.$		-	2.5	-	Ω	
Turn-on delay time	$t_{d(on)}$	$V_{CE} = 920\text{ V}; V_{GE} = \pm 15\text{ V}; I_{Cmax} = 300\text{ A}; R_G = 3\ \Omega; L = 100\ \mu\text{H}.$	$T_{vj} = 25^\circ\text{C}$ $T_{vj} = 150^\circ\text{C}$	416 536	432 548	480 610	ns ns	
Rise time	t_{ri}		$T_{vj} = 25^\circ\text{C}$ $T_{vj} = 150^\circ\text{C}$	60 65	63 67	75 80	ns ns	
Turn-on energy	E_{on}		$T_{vj} = 25^\circ\text{C}$ $T_{vj} = 150^\circ\text{C}$	39 66	42 71	51 86	mJ mJ	
Turn-off delay time	$t_{d(off)}$		$T_{vj} = 25^\circ\text{C}$ $T_{vj} = 150^\circ\text{C}$	730 900	780 930	880 1040	ns ns	
Fall time	t_{fi}		$T_{vj} = 25^\circ\text{C}$ $T_{vj} = 150^\circ\text{C}$	452 612	476 648	560 760	ns ns	
Turn-off energy	E_{off}		$T_{vj} = 25^\circ\text{C}$ $T_{vj} = 150^\circ\text{C}$	66 93	71 99	85 116	mJ mJ	
Collector-emitter threshold voltage	V_{CE0}		$V_{GE} = +15\text{ V}; T_{vj} = 150^\circ\text{C}; I_{CE1} = 75\text{ A}; I_{CE2} = 300\text{ A}; t_u = 1000\ \mu\text{s}.$		1.009	1.033	1.080	V
On-State slope resistance (IGBT)	r_{CE0}				5.73	6.11	6.68	m Ω
Thermal resistance junction to case	$R_{th(j-c)}$		DC; $I_{test} = 1.5\text{ A}; V_{GE} = +15\text{ V}.$		-	0.0761	0.0810	K/W
Inverse diode \ Freewheeling diode								
Forward voltage drop	V_F	$I_F = 300\text{ A}; V_{GE} = 0; t_u = 1000\ \mu\text{s}.$	$T_{vj} = 25^\circ\text{C}$ $T_{vj} = 150^\circ\text{C}$	2.08 2.38	2.13 2.46	2.33 2.71	V V	
Reverse recovery time	t_{rr}	$V_{GE} = \pm 15\text{ V}; V_{CE} = 920\text{ V}; I_{Cmax} = 300\text{ A}; R_{Gon} = 3\ \Omega; L = 100\ \mu\text{H}.$	$T_{vj} = 25^\circ\text{C}$ $T_{vj} = 150^\circ\text{C}$	157 288	166 370	190 480	ns ns	
Repetitive peak reverse current	I_{rrm}		$T_{vj} = 25^\circ\text{C}$ $T_{vj} = 150^\circ\text{C}$	287 328	307 352	350 400	A A	
Reverse recovered charge	Q_{rr}		$T_{vj} = 25^\circ\text{C}$ $T_{vj} = 150^\circ\text{C}$	28.0 53.6	29.0 59.0	33.0 69.0	μC μC	
Reverse recovery energy	E_{rec}		$T_{vj} = 25^\circ\text{C}$ $T_{vj} = 150^\circ\text{C}$	44.0 82.0	46.0 86.0	52.0 96.0	mJ mJ	
Threshold voltage	$V_{(T0)}$		$T_{vj} = 150^\circ\text{C}; V_{GE} = 0; t_u = 1000\ \mu\text{s}$		0.960	0.965	1.000	V
Forward slope resistance	r_T				4.71	4.97	5.54	m Ω
Thermal resistance junction to case	$R_{th(jc-D)}$	DC; $I_{test} = 1.5\text{ A}; V_{GE} = +15\text{ V}.$		-	0.14	0.15	K/W	



Module							
Pin resistance	R_{Pxy}	$T_{vj} = 25^{\circ}C.$	$R_{P10/11-3}$	-	0.92	1.00	m Ω
			$R_{P10/11-4}$	-	0.59	1.00	
Parasitic inductance between terminals	L_{Pce}			-	22	-	nH
Thermistor resistance	R_{t25}	$T_{vj} = 25^{\circ}C$		-	5000	-	Ω
		$T_{vj} = 100^{\circ}C$		-	495	-	
Coefficient of temperature sensitivity	$B_{25/50}$	$R_2 = R_{25} \exp [B_{25/50} (1/T_2 - 1/T_1)],$ $T_1 = 298.15 K$		-	3375	-	K
Thermal resistance case to heatsink	R_{thCH}	per module		-	0.009	0.014	K/W
Mounting torque for screws to heatsink	M_s	to heatsink M6		3	-	6	N*m
Mounting torque for terminal screws	M_t	to terminals M5		3	-	6	N*m
Weight	W			-	360	-	g

Notes:

- Insulating material operating temperature 125°C max;
- Case temperature 125°C max;
- The recommended operating junction temperature $T_{vj op} = -40 \div +150^{\circ}C$;
- The information given in the datasheet is preliminary.

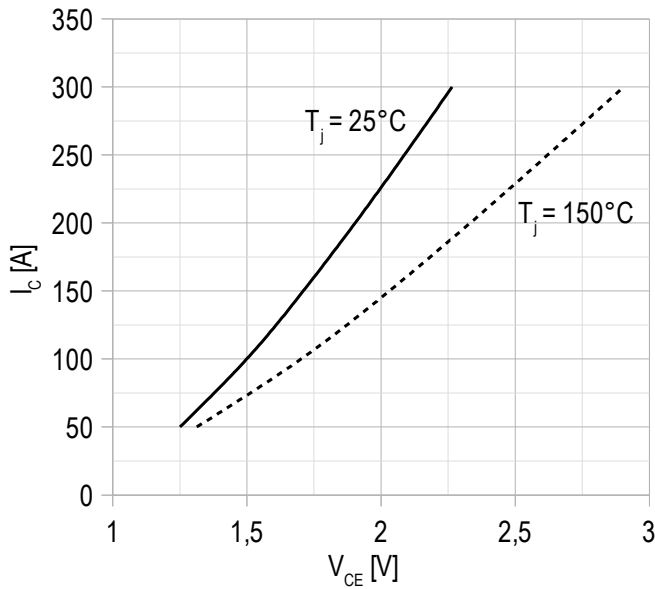
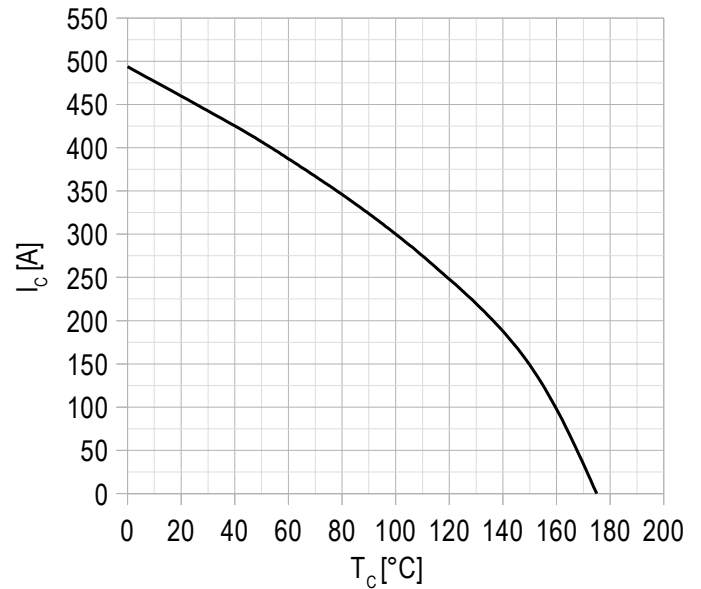
Chart 1 – typ. output characteristic, IGBT.

 $V_{GE} = +15 \text{ V.}$
Chart 2 – max. rated current vs temperature.

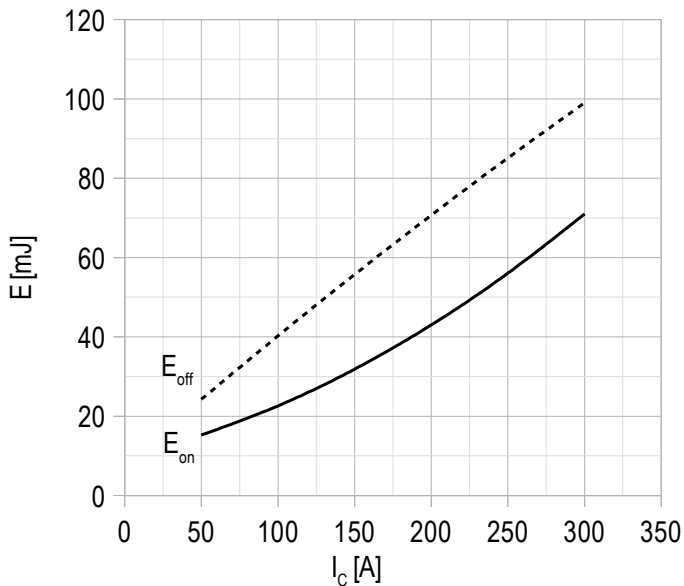
DC;
 $V_{GE} = +15 \text{ V;}$
 $T_{vj(max)} = 150^\circ\text{C.}$

Chart 3 – typ. turn-on/off energy vs rated current, IGBT.

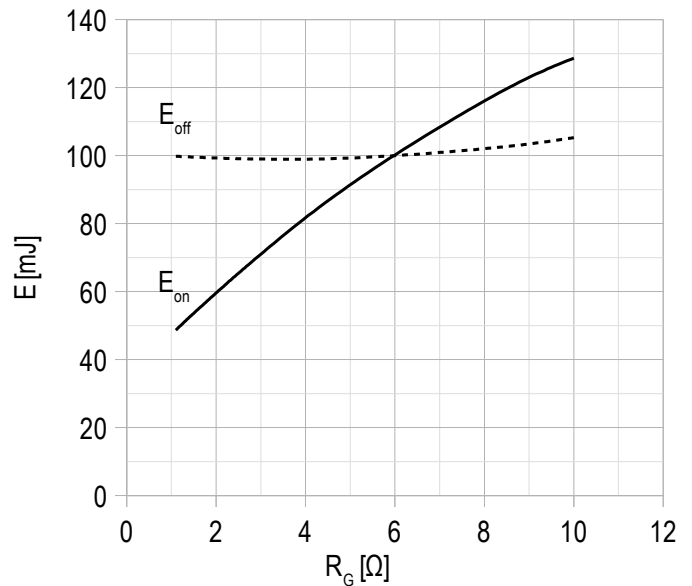
$V_{CE} = 920 \text{ V;}$
 $V_{GE} = \pm 15 \text{ V;}$
 $R_G = 3 \Omega;$
 $L = 100 \mu\text{H;}$
 $T_{vj(max)} = 150^\circ\text{C.}$

Chart 4 – typ. turn-on/off energy vs gate resistance, IGBT.

$V_{CE} = 920 \text{ V;}$
 $V_{GE} = \pm 15 \text{ V;}$
 $I_{Cmax} = 300 \text{ A;}$
 $L = 100 \mu\text{H;}$
 $T_{vj(max)} = 150^\circ\text{C.}$

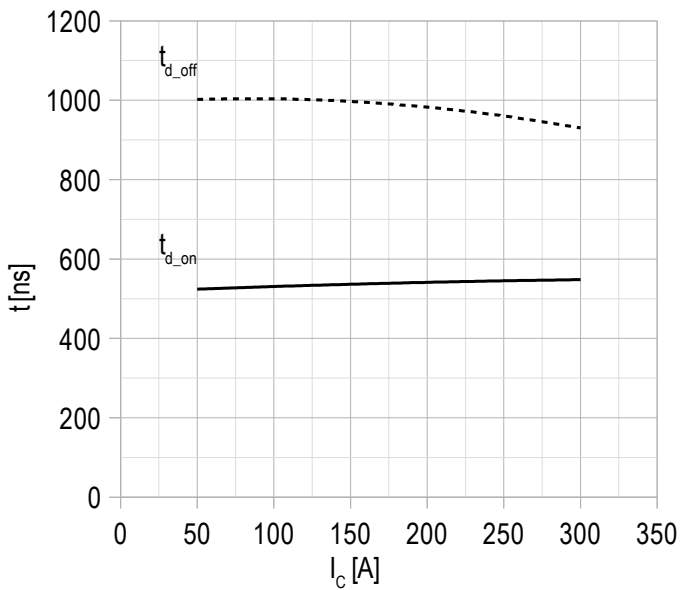
Chart 5 – typ. switching times vs rated current, IGBT.

$V_{CE} = 920$ V;
 $V_{GE} = \pm 15$ V;
 $R_G = 3$ Ω ;
 $L = 100$ μ H;
 $T_{vj(max)} = 150^\circ$ C.

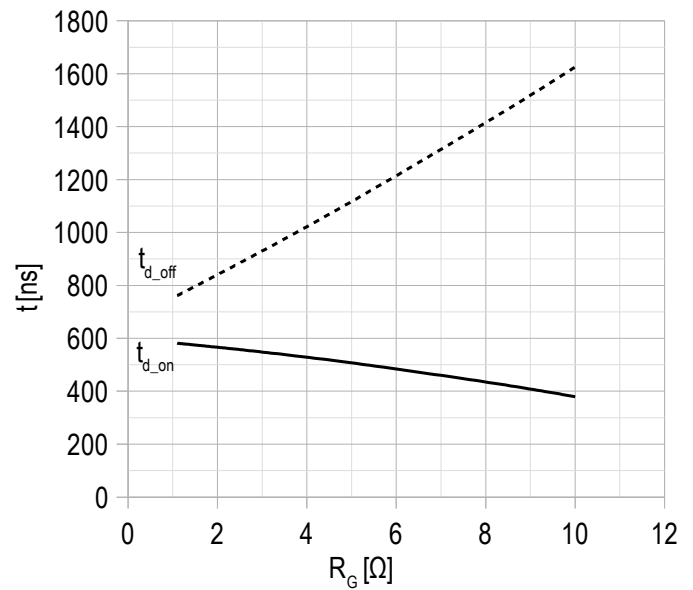
Chart 6 – typ. switching times vs gate resistance, IGBT.

$V_{CE} = 920$ V;
 $V_{GE} = \pm 15$ V;
 $I_{Cmax} = 300$ A;
 $L = 100$ μ H;
 $T_{vj(max)} = 150^\circ$ C.

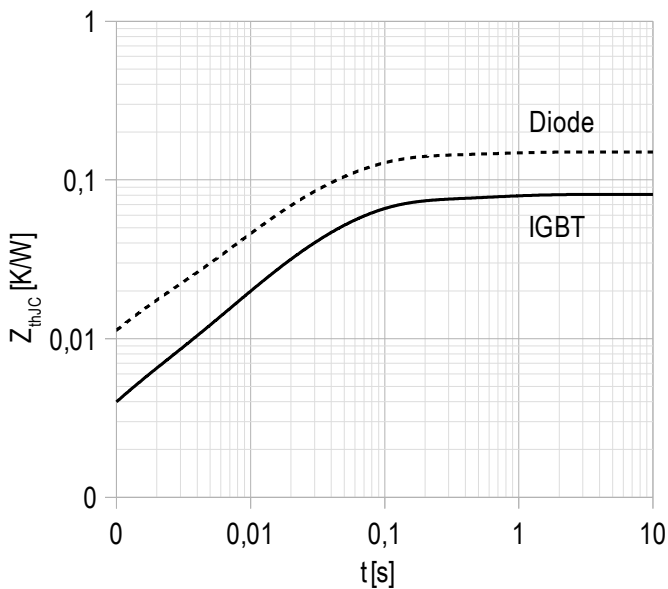
Chart 7 – max. transient thermal impedance.

Single pulse;
 $V_{GE} = +15$ V.

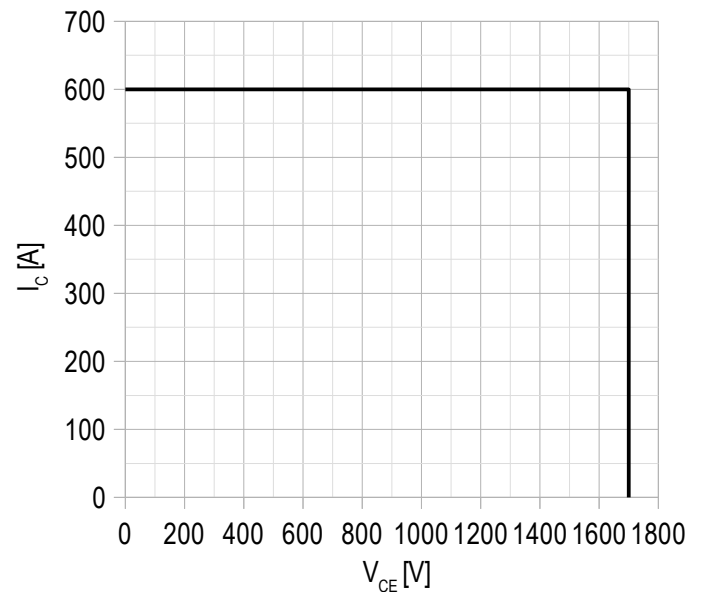
Chart 8 – RBSOA.

$V_{CEmax} = 1700$ V;
 $V_{GE} = \pm 15$ V;
 $I_{Cmax} = 2 \cdot I_{Cnom}$;
 $R_G = 3$ Ω ;
 $L = 100$ μ H.

Chart 9 – typ. output characteristic, FRD.

 $V_{GE} = +15\text{ V}$.

Chart 10 – typ. switching losses vs rated current, FRD.

 $V_{GE} = \pm 15\text{ V}$;
 $V_{CE} = 920\text{ V}$;
 $L = 100\ \mu\text{H}$;
 $R_{G\ on} = 3\ \Omega$;
 $T_{vj\ (max)} = 150^\circ\text{C}$.

Chart 11 – typ. switching losses vs gate resistance, FRD.

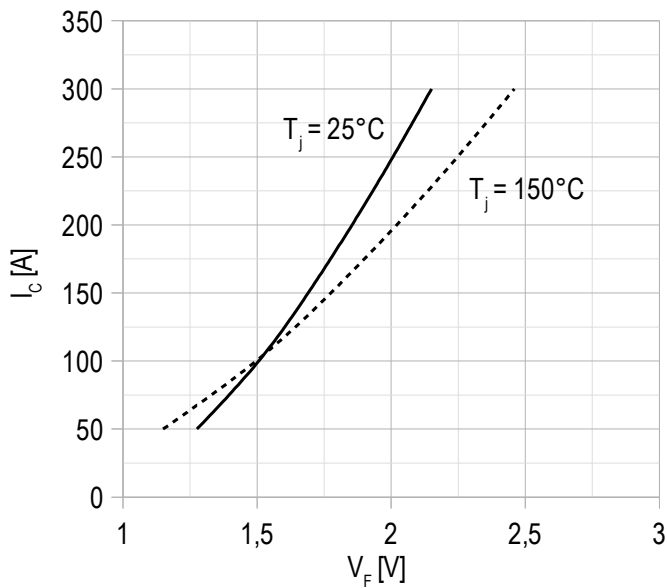
 $V_{GE} = \pm 15\text{ V}$;
 $V_{CE} = 920\text{ V}$;
 $I_{C\ max} = 300\text{ A}$;
 $L = 100\ \mu\text{H}$;
 $T_{vj\ (max)} = 150^\circ\text{C}$.

Chart 12 – typ. reverse recovered charge vs gate resistance, FRD.

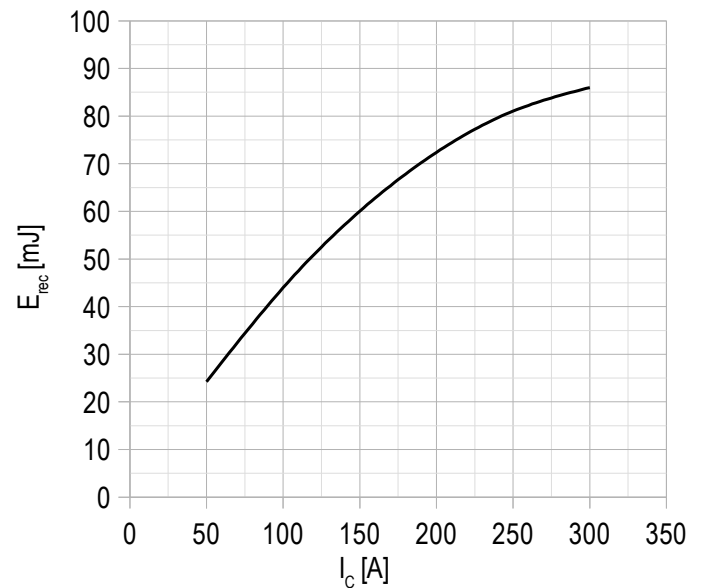
 $V_{GE} = \pm 15\text{ V}$;
 $V_{CE} = 920\text{ V}$;
 $I_{C\ max} = 300\text{ A}$;
 $L = 100\ \mu\text{H}$;
 $T_{vj\ (max)} = 150^\circ\text{C}$.

Chart 13 – typ. switching times vs rated current, FRD.

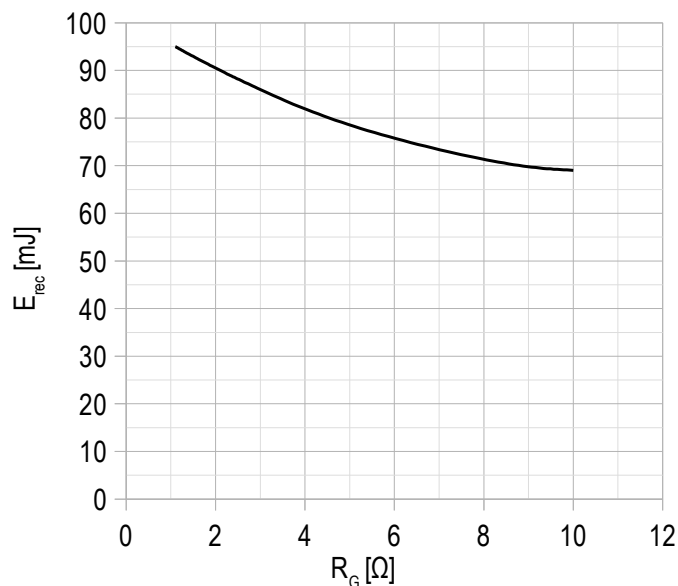
$V_{CE} = 920$ V;
 $V_{GE} = \pm 15$ V;
 $R_G = 3$ Ω ;
 $L = 100$ μ H.
 $T_{vj(max)} = 150^\circ$ C.

Chart 14 – typ. switching times vs gate resistance, FRD.

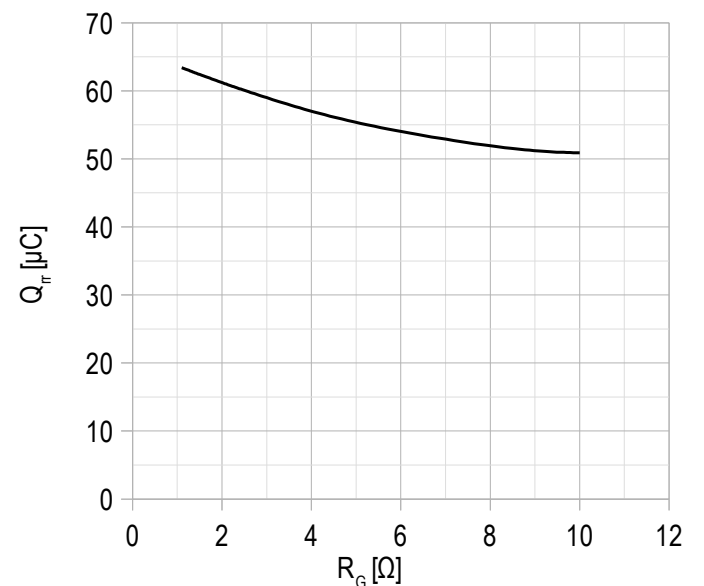
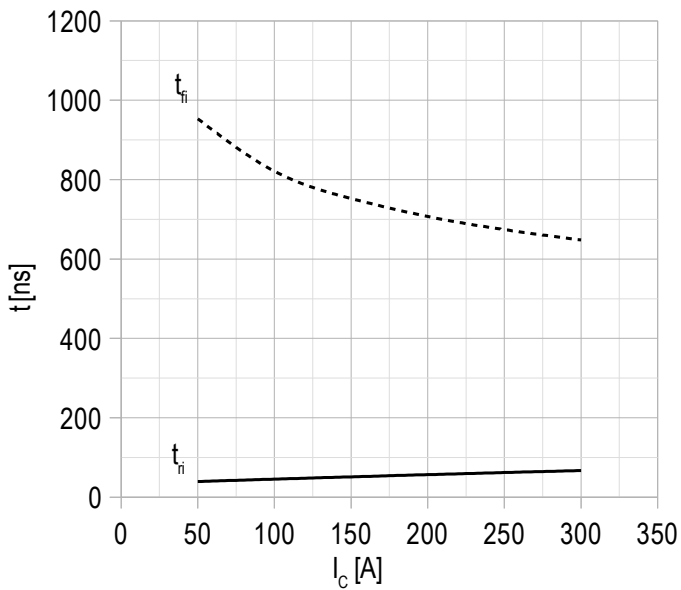
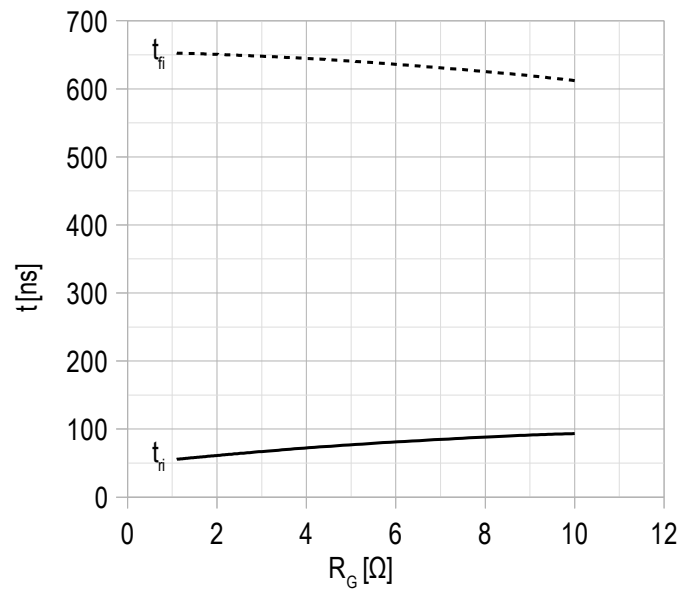
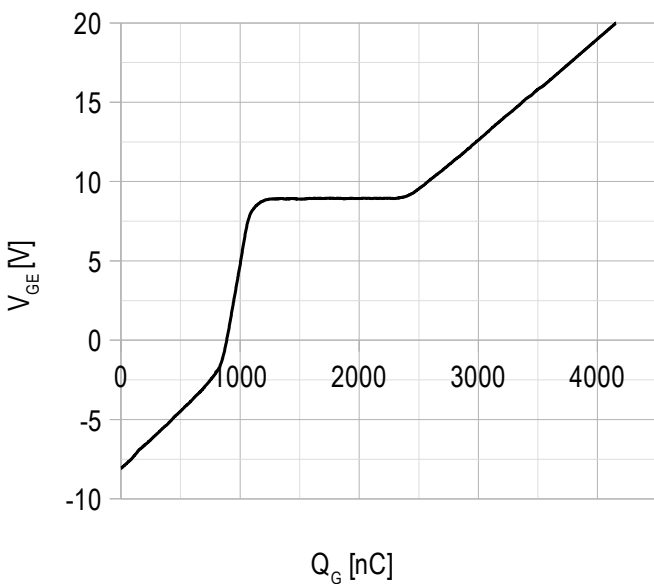
$V_{CE} = 920$ V;
 $V_{GE} = \pm 15$ V;
 $I_{Cmax} = 300$ A;
 $L = 100$ μ H.
 $T_{vj(max)} = 150^\circ$ C.

Chart 15 – typ. gate charge characteristic.

$I_c = 300$ A;
 $V_{CE} = 920$ V;
 $V_{GE} = -8 \div 15$ V.

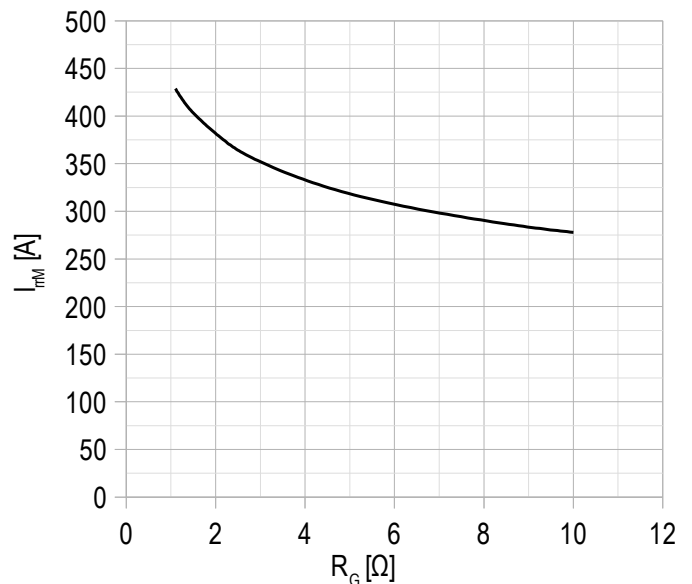
Chart 16 – typ. reverse recovery current vs gate resistance FRD.

$V_{CE} = 920$ V;
 $V_{GE} = \pm 15$ V;
 $L = 100$ μ H.
 $T_{vj(max)} = 150^\circ$ C.

Chart 17 – typ. rated current vs frequency.

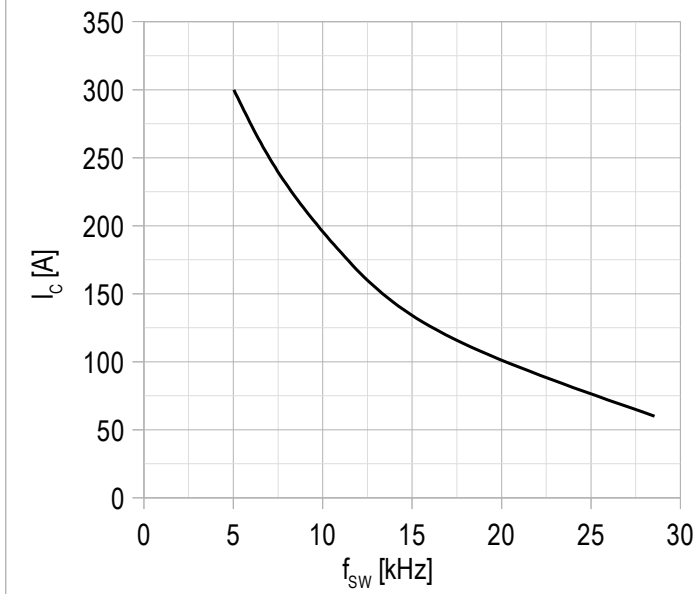

Duty cycle 50%

Overall dimensions: Package type – DA

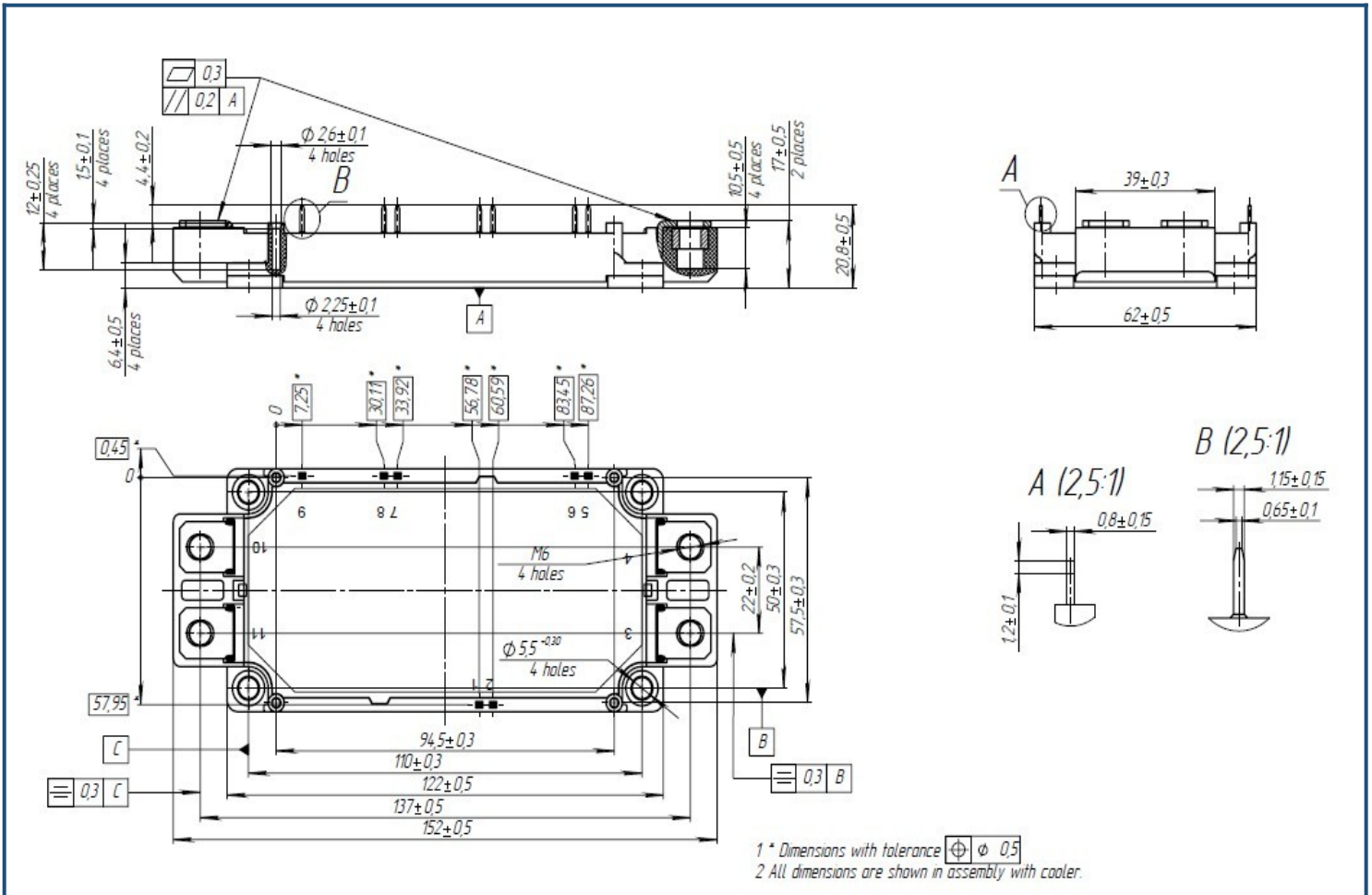

Part numbering guide

MIDA	-	HB	17	FA	-	300	N	
MIDA								IGBT module package type: DA
		HB						Half-Bridge
			17					Voltage rating ($V_{CES}/100$)
				FA				IGBT+FRD chipset modification
						300		Current Rating
							N	Climatic version: normal climate

The information contained herein is protected by Copyright. In the interest of product improvement, Proton-Electrotex reserves the right to change datasheet without notice.